

# SURGICAL SUCTION DEVICE

MODEL: NOVELA THORACIC  
ORDER NUMBER: 33.1027

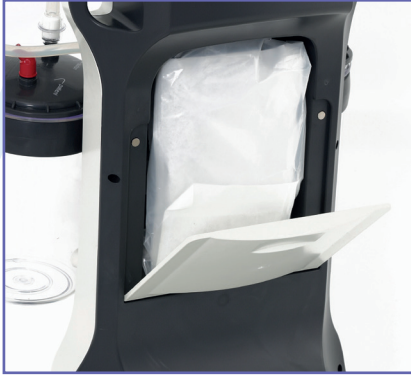

## PRODUCT FEATURES

### General Features

Type and Number of Jars	Polycarbonate Jars
Jar Capacity Options	2x3 L
Input Voltage	220-240 V AC / 50-60 Hz
Flow Rate	8 L/Min
Max. Vacuuming Power	680 mmHg (~90kPa, 0,90 bar) (at sea level)
Max. Noise Level	Max. 55 dB
Pump	Oil-free type
Filter	7 pcs

### Dimensions

Packing Weight	25 kgs
Packing Size (WxLxH)	510x510x960 mm

Accessories Packing Size / Weight 3L: 330x450x210mm/3kg

### Classification

Applicable certificates of the product : TS EN 60601-1, EN ISO 10079-1:2015 EN 60601-1-2:2015/A1:2021, EN 60601-1-6:2010

The product is manufactured in line with ISO 10079-1 standard.

Surgical suction units are classified as Class IIa medical devices and CE-certified.

### STANDART ACCESSORIES AND SPARE PARTS

- PC Jar 1 pair (includes lid, gasket, overflow valve)
- Probe Container and Holder
- Hydrophobic Filter 5 pcs
- Hose adapter: 2 pcs
- Silicone Hose (50 cm) 2 pcs
- Connector 2 pcs
- Yankuer hose 2 pcs

# SURGICAL SUCTION DEVICE

MODEL: NOVELA THORACIC

ORDER NUMBER: 33.1027

## TECHNICAL DRAWING

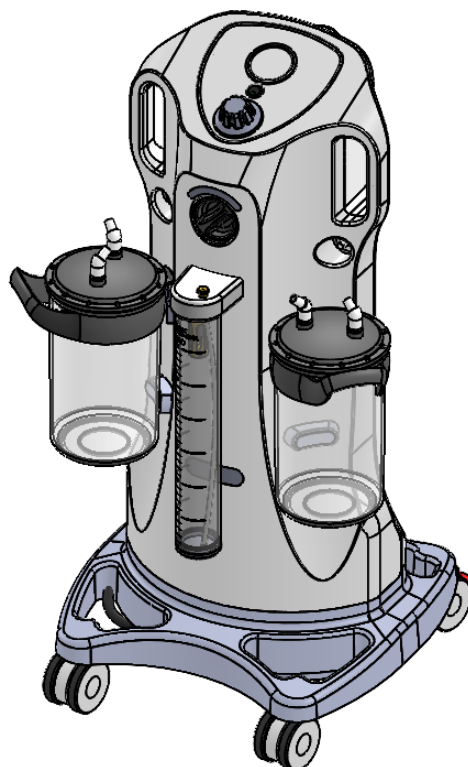
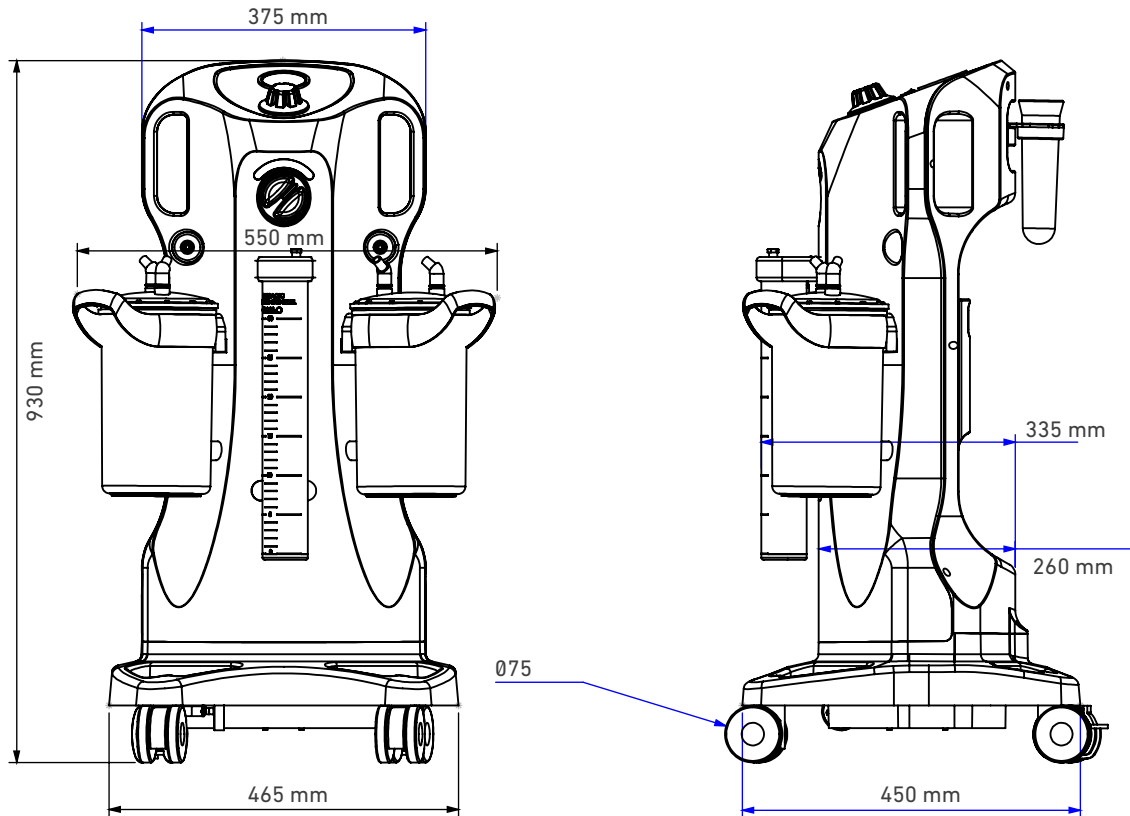

### NOTES:

- Units are in "mm"
- Tolerances:  $\pm 25$  for metric measurements  
 $\pm 5$  for angle measurements