

MINI VACUUM STATION

Features

- Compact and independent: Ready-to-use vacuum unit
- Oil-lubricated rotary vane vacuum pump
- Standard inlet connection
- Optional components:
 - *Aspiration-type bacterial filter
 - *Bacterial box drain
 - *Liquid trap
- Quiet operation (Low noise level)
- High efficiency and reliability
- Sensitivity to foreign particles: An additional filter is integrated into the intake line
- Not suitable for corrosive systems
- Complex and durable design
- 2-3 different phase options can be offered according to customer needs
- Different colored light indicators should be present in the system during operation
- Vacuum tank made of cast iron for durability
- Maintenance plan:
 - *Regular maintenance: After 3,000 hours of operation
 - *Preventive maintenance: After 12,000 hours of operation



66.1323

	VPY-70/66.1323	VPY-71/66.1322
Nominal Capacity (m ³ /h) 50 Hz	25	2x10
Power (kW) 50 Hz	0,75	2x0.35
Tank Capacity (L)	70	70
Noise Level dB(A)	60	60
Oil Capacity (L)	1,5	1,5
Weight (kg)	85	85



66.1322

TECHNICAL DRAWING

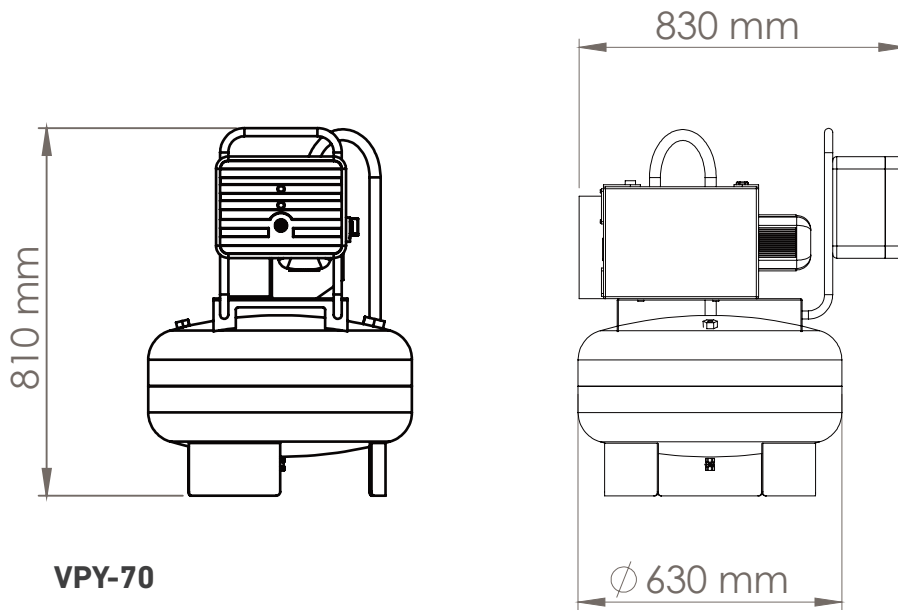

VPY-70

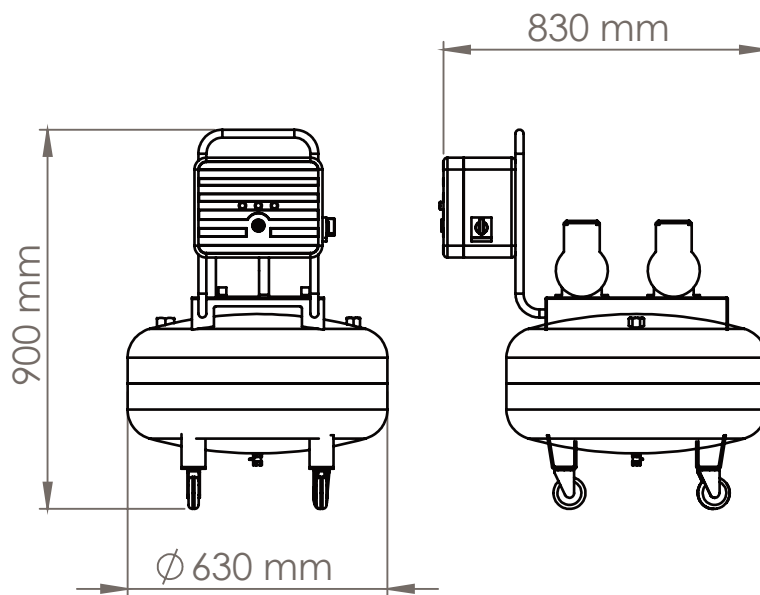

VPY-71