

# TRIPLE HEAD OPERATING LIGHT

MODEL: DL-662D  
ORDER NUMBER: 22.1097

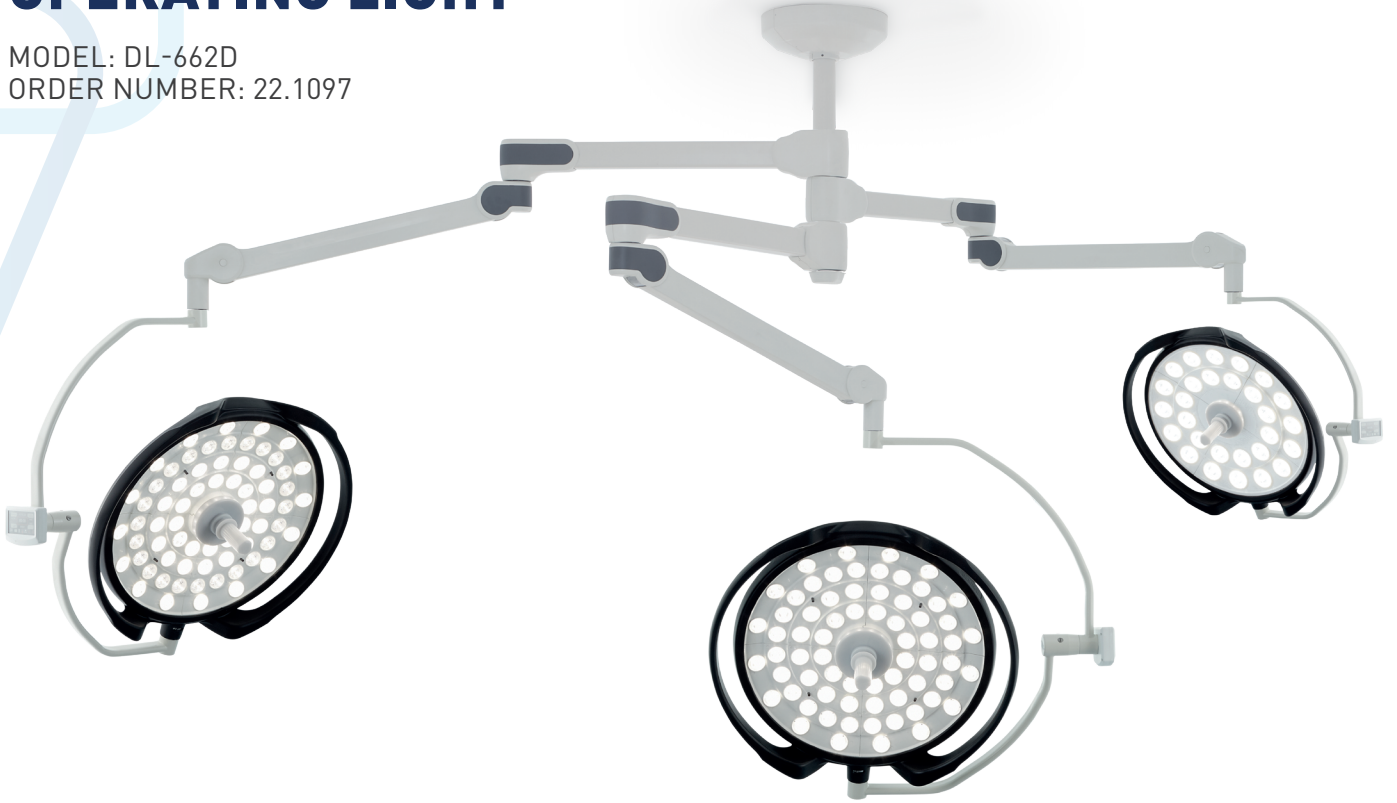

## PRODUCT FEATURES

UZUMCU LED operating lights are designed to meet all lighting and viewing requirements of operating theatres. Powerful LED technology with high-tech camera solution helps the surgeons to operate and view the surgery area clearly. UZUMCU LED lights can be adapted in any size of operating theatres including large hybrid types with variety of models & combinations.

### General Features

Lamp Features	LED Lamp
Arm Joint Type	Spring Type Joint Arms
Classification	Class I – EU 2017/745 MDR
Regulatory Compliance	CE
Standards	EN 60601-1, EN IEC 60601-2-41, EN 60601-1-2

### Material Specifications

Header Plate	ABS
Handle Material	Polyurethane
Horizontal Arms	Aluminum
Cardanic Arms	Static Painted (RAL 9002)
Sterile Handle Material	ABS + PC

### Recommendation

The handle should be sterilized at 134 °C between 3,5-5 minutes and at 121°C during 10 minutes

# TRIPLE HEAD OPERATING LIGHT

MODEL: DL-662D  
ORDER NUMBER: 22.1097

Tehnicial Specifications	Main Lighthouse	Satellite Lighthouse
Diameter of Lighthouse	Ø640 mm	Ø 430 mm
Adjustable Focus Diameter	150 – 300 mm	140 – 170 mm
Spring Lamp Arm Length	910 mm	910 mm
Spring Lamp Arm Movement Angle	+45° / -70°	+45° / -70°
Ceiling Mount Arm	360°	360°
Color Rendering Index, CRI	Ra>96	Ra>96
Color Temperature	3500K-5000K adjusted	3500K-5000K adjusted
Light Power	160.000 lux	120.000 lux
Light Intensity Adjustment	1-100 %	1-100 %
Temperature Increase on The Surgical Area	< 0,5°C	< 0,5°C
Led Module Quantity	68	28
Led Life	> 60.000 hours	> 60.000 hours
Total Consumption Nominal	85 W	55 W
Main Voltage	100-120V AC/ 4.0A 200-240V AC/ 2.0A 50-60 Hz	100-120V AC/ 4.0A 200-240V AC/ 2.0A 50-60 Hz
Operating Voltage	24 VDC	24 VDC
Lighting Depth (L1+L2 %60)	>71 cm	>92 cm
UV Radiation Intensity	0,2 W/m <sup>2</sup>	0,2 W/m <sup>2</sup>
Radiant Energy	3,3 mW/m <sup>2</sup> lx	3,5 mW/m <sup>2</sup> lx
Irradiance With Nominal Illuminance	531 W/m <sup>2</sup>	430 W/m <sup>2</sup>
Total Weight Head and Cardanic Arms	16 kgs	9 kgs

## TECHNICAL DRAWING

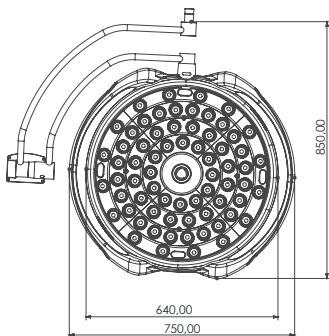
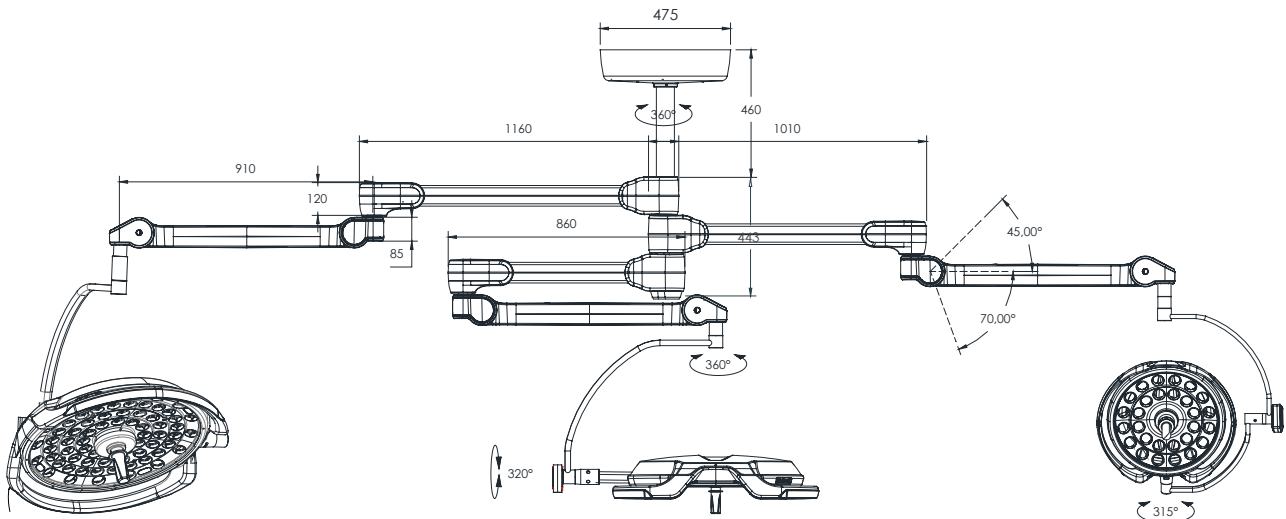

- Units are in "mm"
- Note: ± 25 mm tolerance is given for metric measurements and ± 5° tolerance is given for angle measurements.

