

EXAMINATION LIGHT

MODEL: ML-45L
ORDER NUMBER: 22.1111



PRODUCT FEATURES

General Features

Lamp Head	Single
Jointed Arm Features	Spiral Arm
Wheel Features	5 Wheels ,two of them with Brake (Ø50x45mm)
Gross Weight	5,3 kg
Packaging Dimensions	310X1750X140 mm
Classification	Class I – EU 2017/745 MDR
Regulatory Compliance	CE
Standards	EN 60601-1, EN 60601-1-2, EN IEC 60601-2-41

Electrical Features

Lamp Life	60.000 hours
Inlet Voltage	220-240 VAC, 50-60 Hz
Working Voltage	24 V DC
Electrical Protection Class	Class I

Optical Properties

Lamp Head Dia.	Ø100mm
Illumination, Ec	30.000 lux / 0,4 m

Material Specifications

Lamp Head Material	ABS
Spiral Arm Material	Chrome Plated Spiral

EXAMINATION LIGHT

MODEL: ML-45L

ORDER NUMBER: 22.1111

TECHNICAL DRAWING

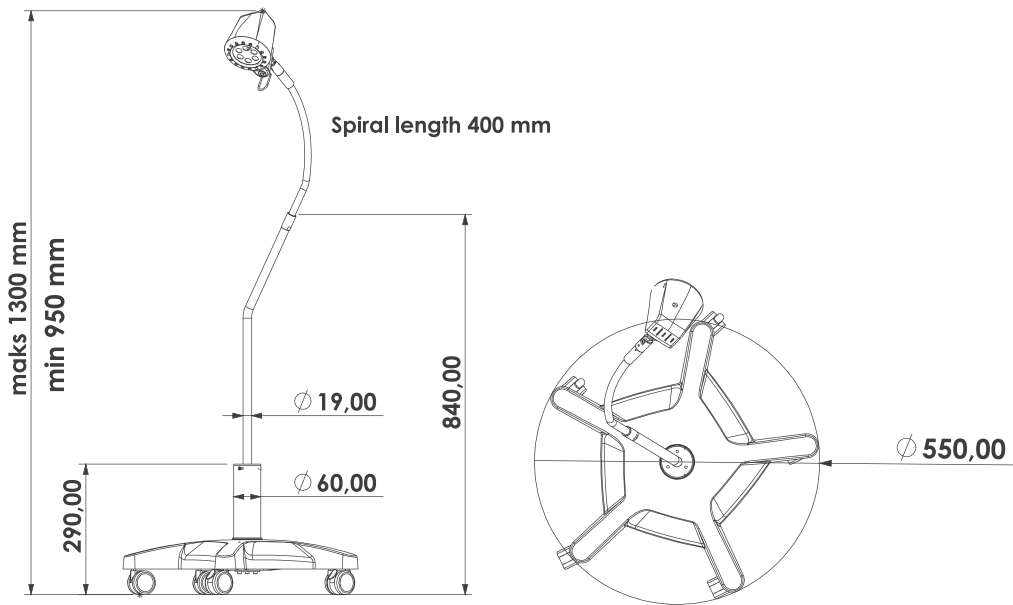

• Units are in "mm"

• Note: ± 25 mm tolerance is given for metric measurements and $\pm 5^\circ$ tolerance is given for angle measurements.