

# PORTABLE SUCTION DEVICE

MODEL: PA-2, PORTABLE  
ORDER NUMBER: 33.1005



## PRODUCT FEATURES

### General Features

Type and Number of Jars Jar Capacity Options	Polycarbonate Jar 1 x 2 L
Power	220-240 V AC / 50-60 Hz /12 V DC
Pump	Oil-free type
Flow Rate	22 L/min
Max. Vacuuming Power	0-630 mmHg (at sea level)
Noise	65 dBA
Device Weight	3,2 kgs

### Dimensions

Packing Weight	4,6 kgs
Packing Size (mm <sup>3</sup> ) (WxLxH)	230x420x370 mm

### Classification

Applicable certificates of the product : TS EN 60601-1,  
EN ISO 10079-1:2015 EN 60601-1-2:2015/A1:2021, EN 60601-1-6:2010

The product is manufactured in line with ISO 10079-1 s tandand.

Surgical suction units are classified as Class IIa medical devices  
and CE-certified.

### STANDART ACCESSORIES AND SPARE PARTS

- 2 meter of Silicone Suction Hose
- 1 pc 2 liters Vacuum Jar
- 3 pcs Hydrophobic Filter
- 1 pc Catheter Jar
- 1 pc Energy Cable
- 1 pc Conical Connector

# PORTABLE SUCTION DEVICE

MODEL: PA-2, PORTABLE  
ORDER NUMBER: 33.1005

## TECHNICAL DRAWING

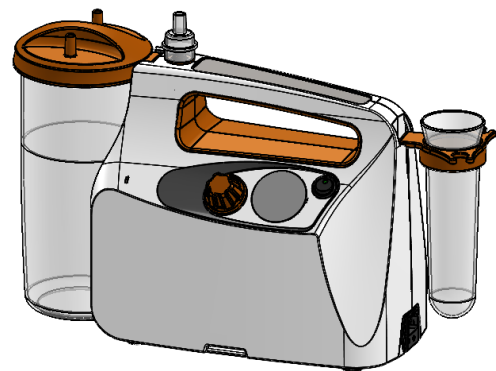
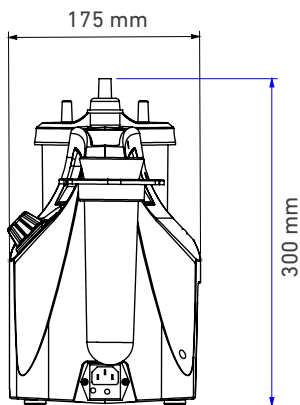
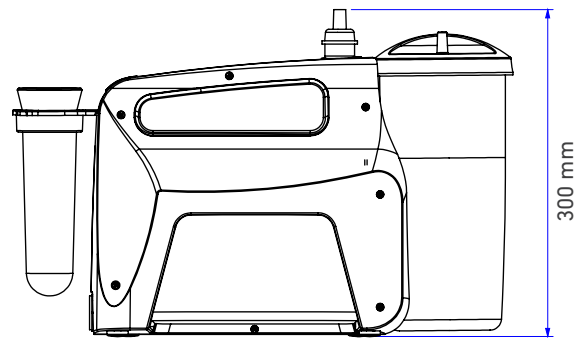
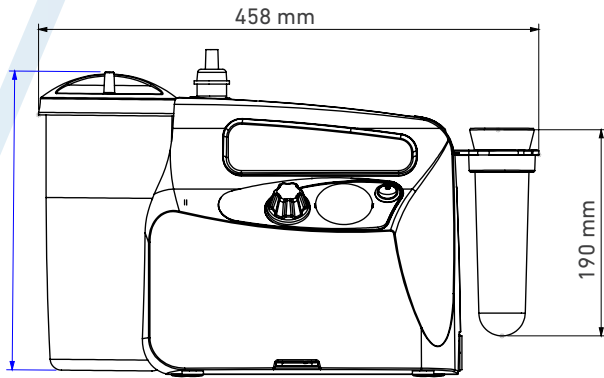

### NOTES:

- Units are in "mm"
- Tolerances:  $\pm 25$  for metric measurements  
 $\pm 5$  for angle measurements