

PORTABLE SUCTION DEVICE

MODEL: PA-1R,
PORTABLE WITH BATTERY
ORDER NUMBER: 33.1004



PRODUCT FEATURES

General Features

| | |
|-------------------------|---------------------------|
| Type and Number of Jars | Polycarbonate Jar |
| Jar Capacity Options | 1 x 2 L |
| Power | 12 V DC |
| Pump | Oil-free type |
| Flow Rate | 22 L/min |
| Max. Vacuuming Power | 0-450 mmHg (at sea level) |
| Noise | 65 dBA |
| Device Weight | 4 kgs |

Dimensions

| | |
|---|----------------|
| Packing Weight | 5,4 kgs |
| Packing Size (mm ³) (WxLxH) | 230x420x370 mm |

Classification

Applicable certificates of the product : TS EN 60601-1, EN ISO 10079-1:2015 EN 60601-1-2:2015/A1:2021, EN 60601-1-6:2010

The product is manufactured in line with ISO 10079-1 s standard.

Surgical suction units are classified as Class IIa medical devices and CE-certified.

STANDART ACCESSORIES AND SPARE PARTS

- 2 meter of Silicone Suction Hose
- 1 pc 2 liters Vacuum Jar
- 3 pcs Hydrophobic Filter
- 1 pc Catheter Jar
- 1 pc Energy Cable
- 1 pc Conical Connector

PORTABLE SUCTION DEVICE

MODEL: PA-1R, PORTABLE WITH BATTERY
ORDER NUMBER: 33.1004

TECHNICAL DRAWING

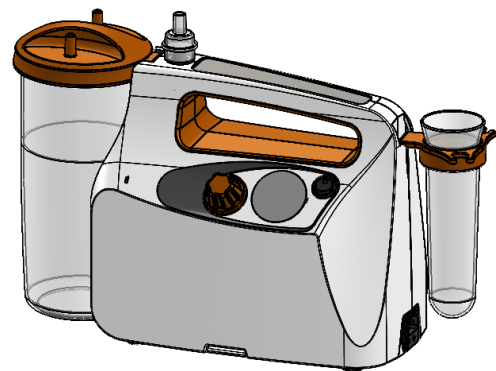
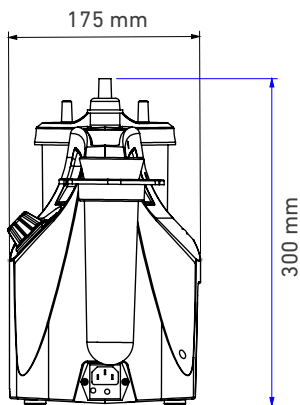
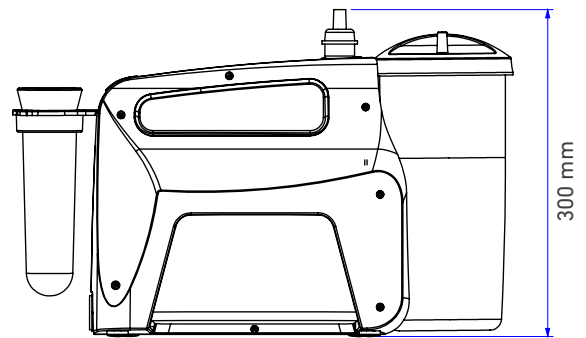
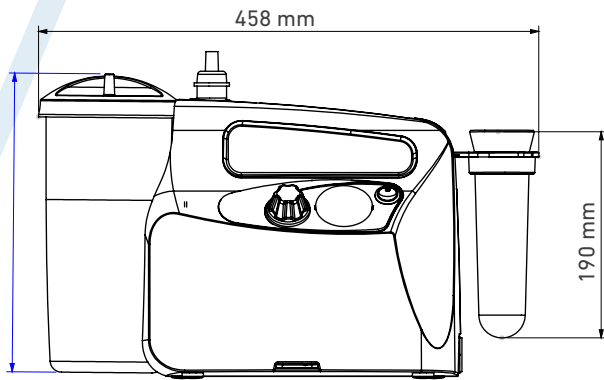

NOTES:

- Units are in "mm"
- Tolerances: ± 25 for metric measurements
 ± 5 for angle measurements